



Double-level Platform Scissor Alignment Lift

Double Level Platform Scissor Alignment Lift

Model: GC-5.5MSI

Brand : Latest

Origin : China/Malaysia

(c/w standard accessories)



Model	Power Supply	Air Supply	Power	Lifting Capacity		Lifting Height	
				Main Lift	Second Lift	Main Lift	Second Lift
GC-5.5 MSI	380V/3Ph or 220V/1Ph	4 ~6 Bar	3.0KW	5.5T	5.5T	330-1850 mm	450mm

Features:

- ◆ With wheel free lift scissor structure for in ground installation
- ◆ Low voltage control (24V)
- ◆ With antiknock valve and safety valve to ensure the safety
- ◆ Perform stable and reliable
- ◆ Good synchronization and precise levelling for alignment
- ◆ Position of turntable can be adjusted to suit for various types for vehicles
- ◆ Optional choose guide rail and rolling jack (optional part)



● Super-friction materials.

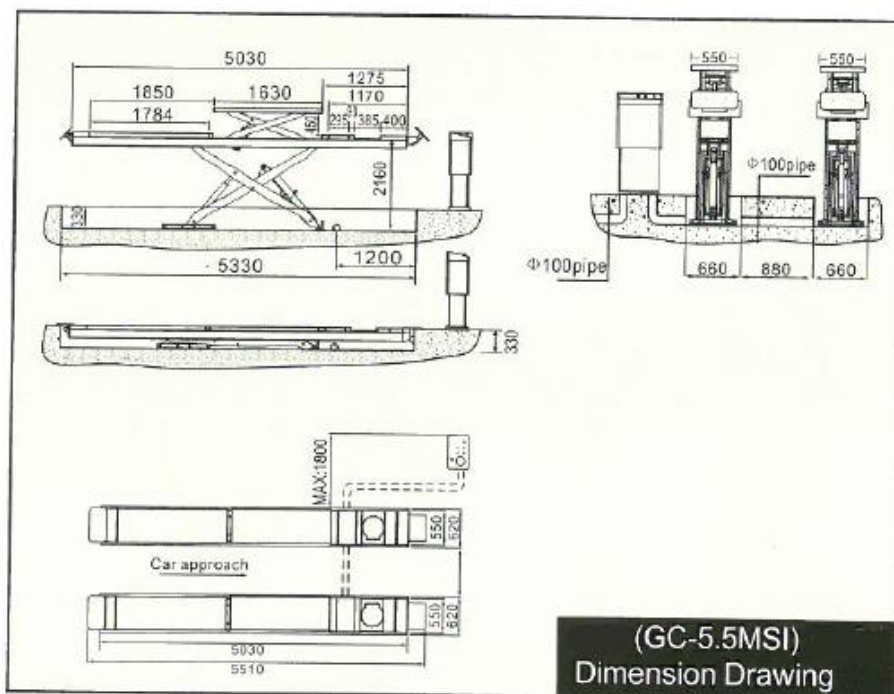

● The pneumatic double-teeth self-locking

(GC-5.5MSI)
Dimension Drawing

Note:

- Above all picture for reference only
- Any changer/alterations of the technical features /specification and appearance of the above products are subject to change (if the manufacturer thinks necessary) without notice given by our company.



**LATEST AUTOMOTIVE TECHNOLOGY SDN.
BHD. 200401037132(675643-X)**

 No.50&50-A, Jalan Seri Rama, Taman Muzaffar Shah,
Ayer Keroh, 75450 Melaka, Malaysia.

 +606-232 8991(Tel)

 +6016-663 3131 +6019-662 8632

 +606-232 3998

 office@latest.com.my