

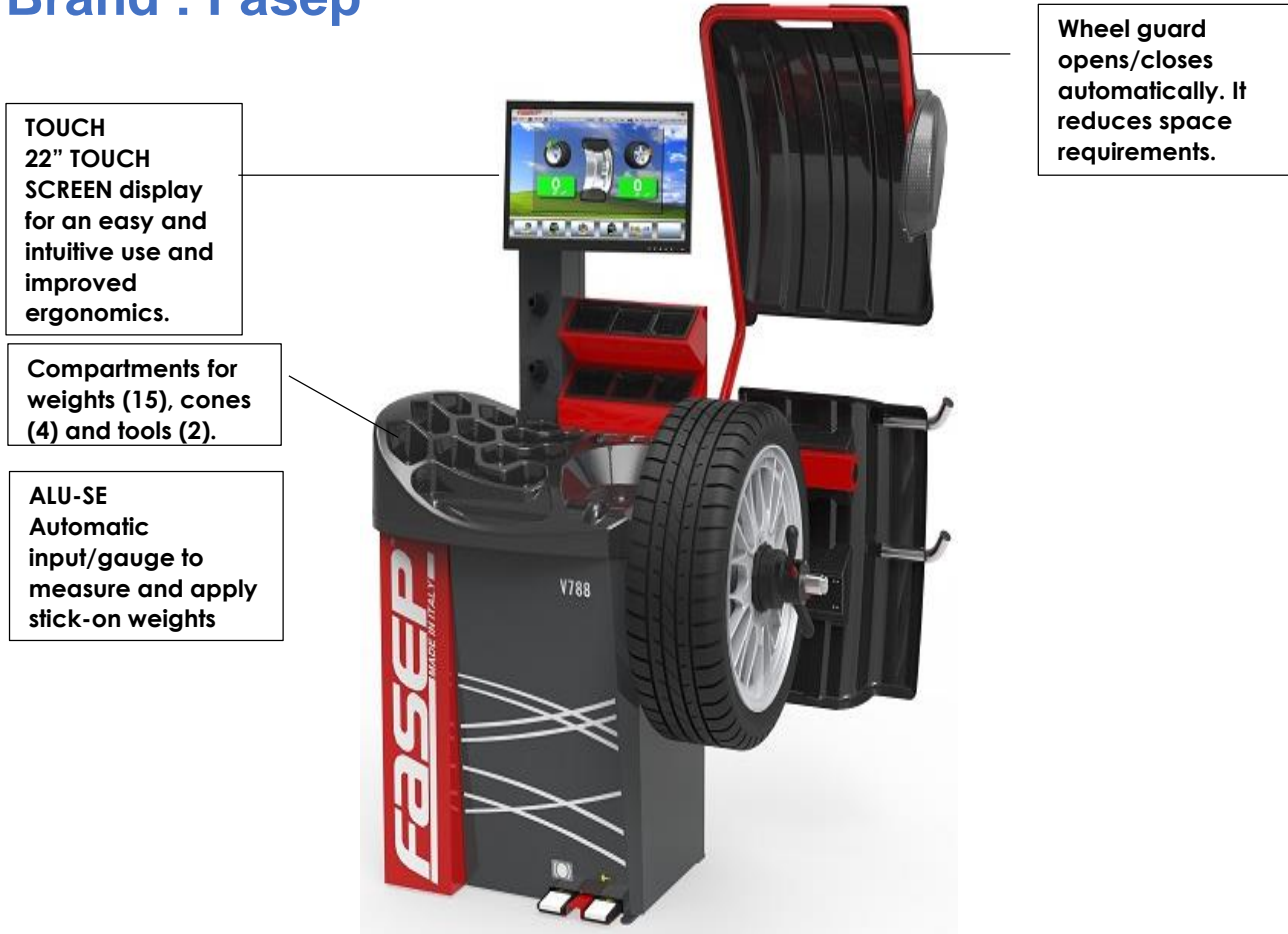

Wheel Balancer

Wheel Balancer Model: V788 Brand : Fasep



**TOUCH
22" TOUCH
SCREEN** display
for an easy and
intuitive use and
improved
ergonomics.

Compartments for
weights (15), cones
(4) and tools (2).

ALU-SE
Automatic
input/gauge to
measure and apply
stick-on weights

Wheel guard
opens/closes
automatically. It
reduces space
requirements.

The new generation.

V788 offers everything All-Inclusive. The 3D Touchless input system allows the automatic measurement of the wheel (distance + diameter + width) for both aluminum rims and steel rims, allowing in an absolutely automatic way the balancing with adhesive weights or clip weights, respectively. V788 includes a 22 "Touch screen for maximum ease of work, laser for the application of any type of weight with maximum precision, 3D.Wall for checking tire and rim geometry, and G3.Extreme electronics for the maximum working speed The new arrangement of the Pneu-lock and Brake controls, thanks to two new pedals, allows greater ease of use.

Note:

- Above all picture for reference only
- Any changer/alterations of the technical features /specification and appearance of the above products are subject to change (if the manufacturer thinks necessary) without notice given by our company.

Dimensions

A= 300 mm	C= 1070 mm	E= 1310 mm
B=1080 mm	D= 1770 mm	E1= 1680 mm
B1= 780 mm	D1= 1530 mm	E2= 1380 mm

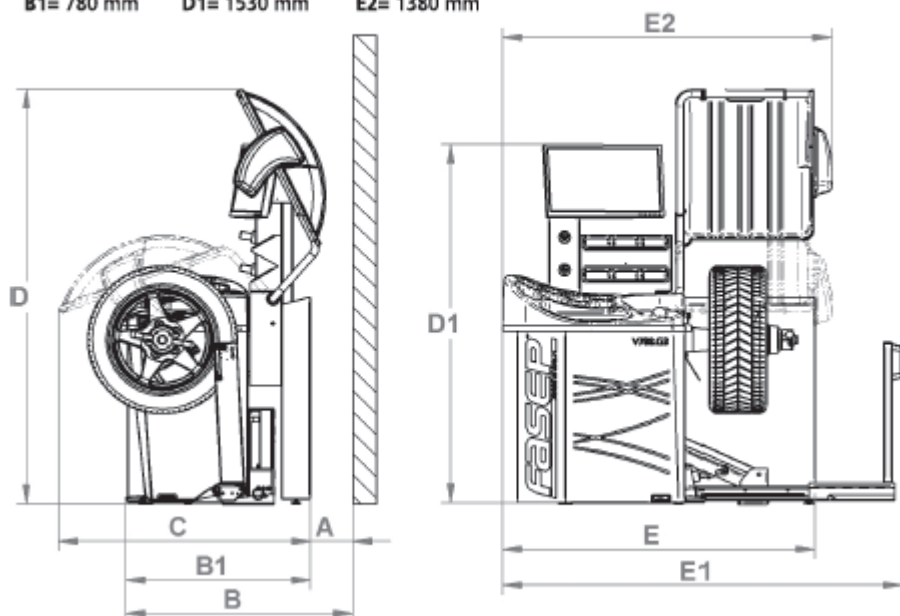

Functions

- User setup
- Allu programs
- Automatic start-stop
- Tyre matching
- Self-calibration, self-diagnostic
- Moto program
- **ALU-SE** Guided application for stick-on weights
- **SPLIT** weight function
- **AFC** Automatic Flange Calibration
- **MARS** Automatic Minimization of residual Static Unbalance
- **ASF** ALU Special Functions
- **APS2** Automatic Positioning System
- **EMS** External Measuring System
- **3D.Scanner** To measure run-out and side-slip
- **3D Touchless** Automatic measure of wheel

Technical Features

- Power source 220V 50-60Hz 1Ph
- Motor power 50W
- Balancing speed 98 RPM
- Rim diameter 8" (200mm), 26" (650mm)
- Wheel diameter (max) with wheel guard 34" (850mm)
- Rim width (max) with wheel guard 16" (415mm)
- Wheel weight (max) 90KG (198lbs)
- Measuring time 4-15s
- Accuracy 1gr.
- Angular accuracy 256 divisions
- Monitor LCD 22"

Note:

- Above all picture for reference only
- Any changer/alterations of the technical features /specification and appearance of the above products are subject to change (if the manufacturer thinks necessary) without notice given by our company.



**LATEST AUTOMOTIVE TECHNOLOGY SDN.
BHD. 200401037132(675643-X))**

 No.50&50-A, Jalan Seri Rama, Taman Muzaffar Shah,
Ayer Keroh, 75450 Melaka, Malaysia.

 +606-232 8991(Tel)

 +6016-663 3131 +6019-662 8632

 +606-232 3998

 office@latest.com.my